

An Educational Metadata Management System using a deductive object-oriented database approach

D. Sampson¹, V. Papaioannou¹, *N. Bassiliades², and I. Vlahavas²

¹Advanced e-Services for the Knowledge Society
Research Unit, Informatics and Telematics Institute,
Centre for Research and Technology – Hellas
42, Arkadias Street, Athens, GR-15234 Greece
{Sampson, vickyp}@iti.gr

²Department of Informatics
Aristotle University of Thessaloniki
54006 Thessaloniki, Greece
{nbassili,vlahavas}@csd.auth.gr

Internet-based education and training offer many potential benefits specific to adult learners with emphasis given to learner-centered and self-directed instruction models empowered by web-based educational resources. Indeed, the recent growth of the World Wide Web (WWW) has greatly increased the amount of information and educational resources available to the education community.

The full exploitation of this mass body of knowledge resources available on the Web, can be, however, compromised, by the difficulty in describing, classifying and maintaining those resources in such a way that they can be retrieved in an “*educationally efficient and effective way*”. Today, the web community has embraced the collection and use of metadata to characterise and index educational resources, which lead to semantically more accurate retrieval of information than search engines. In general sense, metadata is information about data. In the context of resource discovery, descriptive metadata is a characterisation that aims to represent the intellectual content of the resource. The most popular technology for representing metadata is XML (eXtensible Markup Language).

Typically, the educational content providers of an e-learning scenario need an educationally oriented application facilitating editorial and management features for manipulating educational metadata documents. An efficient and effective educational metadata management tool should satisfy a number of requirements derived from different dimensions such as:

- The need of addressing user categories (i.e. learners, content providers)
- The availability of different educational metadata specifications/ standards (i.e. IEEE LOM, DC)
- The emerge of metadata enabling representation technologies (i.e. XML, DTD, XMLSchema).

The basic requirements towards an integrated and generic educational metadata management tool are:

- creation of new and modification of existing educational metadata documents
- data and structure validation of the educational metadata document
- support of any educational metadata standard / specification
- creation of new metadata specification that applies to user’s requirements for each case study (e.g. extension of existing metadata standard)
- support enabling metadata technologies (XML, DTD, XMLSchema)
- mapping of educational metadata files between different specifications/standards
- facilitate content management of the educational metadata documents (e.g. search, retrieve, update data)

The proposed architecture of the EM² tool (Sampson, 2002), combines all the required components towards the implementation of an educational metadata management tool (editors, repositories, associations, management, validation and mapping components) and fulfills the above requirements (figure 1).

This paper proposes an educational metadata management system using a deductive, object-oriented database approach. The EM² tool can provide storage and retrieval of data from the XML metadata files in addition to its features (i.e. authoring, editing, etc) by integrating the X-DEVICE system (Bassiliades, 2000). In figure 2, a graphical representation of the proposed architecture for the cooperation between the two systems is presented.

* Supported by a postdoctoral scholarship from the Greek Foundation of State Scholarships (F.S.S. - I.K.Y.).

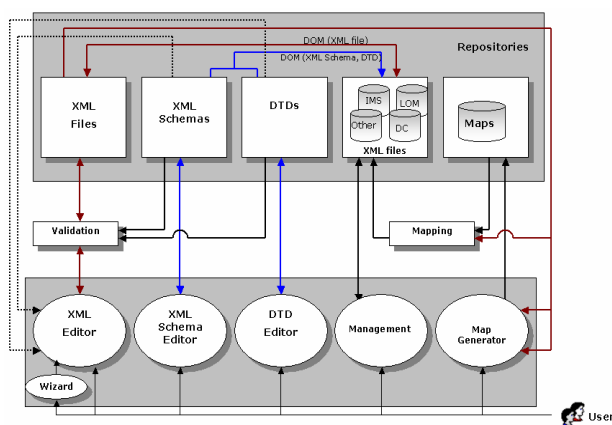

Figure 1: Architecture of an Educational metadata management tool

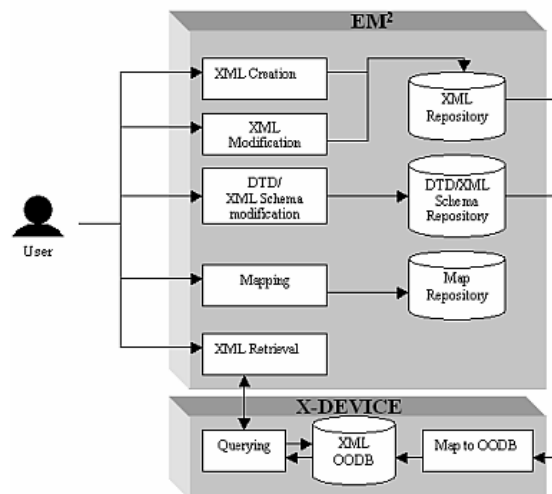

Figure 2: Architecture of EM² and X-DEVICE integration

EM² provides the graphical interface for the interaction with the user. The user can create a new educational metadata file based on metadata specifications, open or edit/update data on an existing one, convert metadata files between specifications as well as create maps for these conversions. The created or modified XML documents after structure and data validation (whenever it is possible) are stored to the associated XML repository of EM². The XML Repository is a system folder storing the XML documents as files, and it is not a database system. In addition the DTD and XMLSchema files are stored in their associated repositories respectively. By integrating X-DEVICE to the EM² tool, database storage and data retrieval can be provided based on the user's queries. Each stored XML document, together with its associated DTD is passed to the X-DEVICE system where the mapping to OODB system takes place. The EM² tool can generate a DTD in case there is no DTD or XML Schema that defines the XML document. In addition, if only an XML Schema exists for a specific XML document then transformation from XML Schema to DTD is also an available feature. The transformation of XMLSchema generates a sample DTD, which may lack information compared to the XMLSchema. The OODB holds the data of every educational metadata file that has been created, updated or stored in the EM² XML repository. In addition, the EM² will provide an interface to the user, for query submission. When specific data is required from the XML documents, the user should compose his query following the syntax of the X-DEVICE system query language. The query is then passed to the X-DEVICE system, which will obtain the required information from the OODB. The information is in XML format and it will be presented to the user through the user interface of EM².

References

- Sampson, D., Papaioannou, V., and Karadimitriou, P. (2002) EM²: an Environment for Editing and Management of Educational Metadata. *Educational Technology & Society Journal of International Forum of Educational Technology & Society and IEEE Computer Society Learning Technology Task Force. Special Issue on Innovations in Learning Technologies.* 5(4).
- Bassiliades, N., Vlahavas, I., and Elmagarmid, A.K. (2000). E-DEVICE: An Extensible Active Knowledge Base System with Multiple Type Support. *IEEE Transactions on Knowledge and Data Engineering.* 12(5).
- Bassiliades, N., Vlahavas I., and Sampson, D. (2002) Integrating XML Data into an Object-Oriented Database System. David Taniar and Wenny Rahayu (editors). *Web-Powered Databases*, Idea Group Publishing, Hershey.